



Large magnet system for improved sensitivity and transient response.
Precision cast and surface treated magnesium cone coupled to a natural rubber surround showing no sign of midrange (edge) resonances.

Gold plated terminals mounted on a stiff glass fibre reinforced plate to reduce contact resistance and improve reliability.

Heavy copper rings mounted above and below the T-shaped pole piece reduce non linear and modulation distortion and increase overload margin.

Extremely stiff and stable injection moulded metal basket keeps the critical components in perfect alignment. Large windows in the basket both above and below the spider reduce sound reflexion, air flow noise and cavity resonance to a minimum.

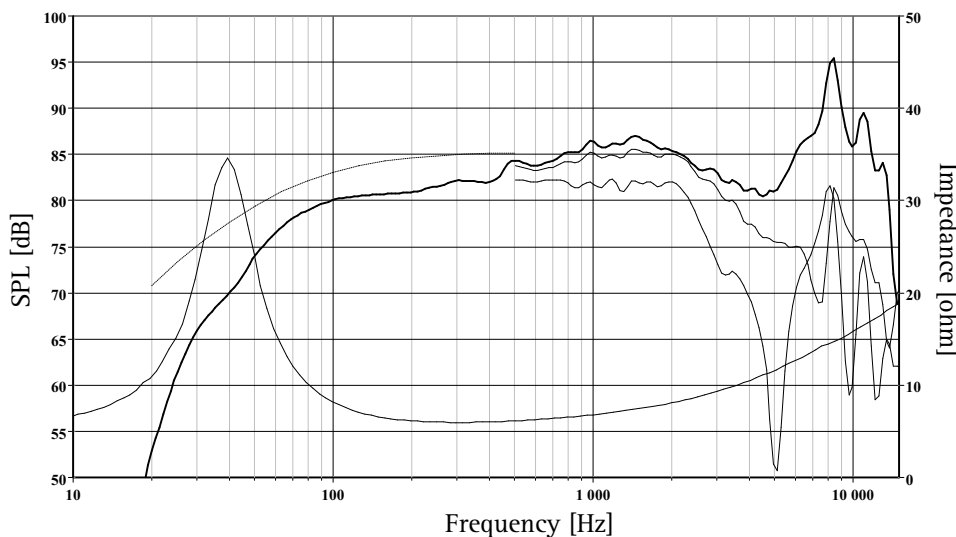

The frequency responses above show measured free field sound pressure in 0, 30, and 60 degrees angle using a 7L closed box. Input 2.83 V_{RMS}, microphone distance 0.5m, normalized to SPL 1m. The dotted line is a calculated response in infinite baffle based on the parameters given for this specific driver. The impedance is measured in free air without baffle using a 2V sine signal.

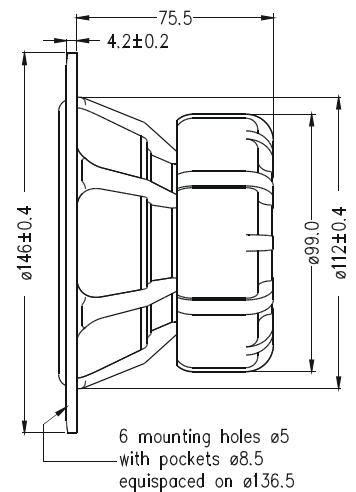

| | | | |
|--|--------------|----------------------------------|--------------------|
| Nominal Impedance | 8 Ohms | Voice Coil Resistance | 5.5 Ohms |
| Recommended Frequency Range | 50 - 3000 Hz | Voice Coil Inductance | 0.49 mH |
| Short Term Power Handling * | 200 W | Force Factor | 5.5 N/A |
| Long Term Power Handling * | 70 W | Free Air Resonance | 38 Hz |
| Characteristic Sensitivity (2.83V, 1m) | 85.5 dB | Moving Mass | 9.5 g |
| Voice Coil Diameter | 26 mm | Air Load Mass In IEC Baffle | 0.38 g |
| Voice Coil Height | 14 mm | Suspension Compliance | 1.8 mm/N |
| Air Gap Height | 6 mm | Suspension Mechanical Resistance | 1.06 Ns/m |
| Linear Coil Travel (p-p) | 8 mm | Effective Piston Area | 75 cm ² |
| Maximum Coil Travel (p-p) | 14 mm | VAS | 14 Litres |
| Magnetic Gap Flux Density | 1.10 T | QMS | 2.22 |
| Magnet Weight | 0.42 kg | QES | 0.43 |
| Total Weight | 1.35 kg | QTS | 0.36 |